



Airborn Regulator

User Manual

Dual Burst Disk

PLEASE READ ALL ENCLOSED INSTRUCTIONS BEFORE ATTEMPTING ANY INSTALLATION OR MAINTENANCE OF THIS PRODUCT. SERIOUS INJURY OR DEATH CAN OCCUR WHEN DEALING WITH COMPRESSED GAS EQUIPMENT.

Arrow Precision Limited, Unit 7 Elliott Industrial Park, Eastern Road, Aldershot, Hampshire, GU12 4TF, UK
Tel: +44 (0)1252 408 552 Fax: +44 (0)1252 408 551
Email: sales@arrow-precision.com

© Copyright Arrow Precision Limited 2007
All rights reserved. No unauthorised reproduction.

WARNING

PLEASE READ ALL ENCLOSED INSTRUCTIONS. SERIOUS INJURY OR DEATH CAN OCCUR WHEN DEALING WITH COMPRESSED GAS EQUIPMENT.

Only attempt any installation or maintenance if you are a fully competent Qualified Person. If in any doubt return the unit to Arrow Precision Limited.

Qualified Persons:

The described equipment should be installed, configured, operated, and serviced only by qualified persons thoroughly familiar with this User's Manual.

For the purpose of this manual, a qualified person is one who is familiar with the installation, assembly, commissioning, and operation of the product, and who has the appropriate qualifications for their activities such as:

Training, instruction, or authorization to operate and maintain devices/systems according to the safety standards for high pressures. Training or instruction according to the safety standards in the care and use of suitable safety equipment.

A copy of this manual accompanies the equipment. The current version of the manual, in Portable Document Format (PDF), can be downloaded from www.powerball.co.uk.

The Airborn Regulator is designed to be fully rebuildable. All replacement parts and service tools are available from Arrow Precision Limited.

The regulator should provide many years of trouble free use given proper care and maintenance. All parts are replaceable and available from Arrow Precision. Please refer to assembly drawing for part numbers and description.

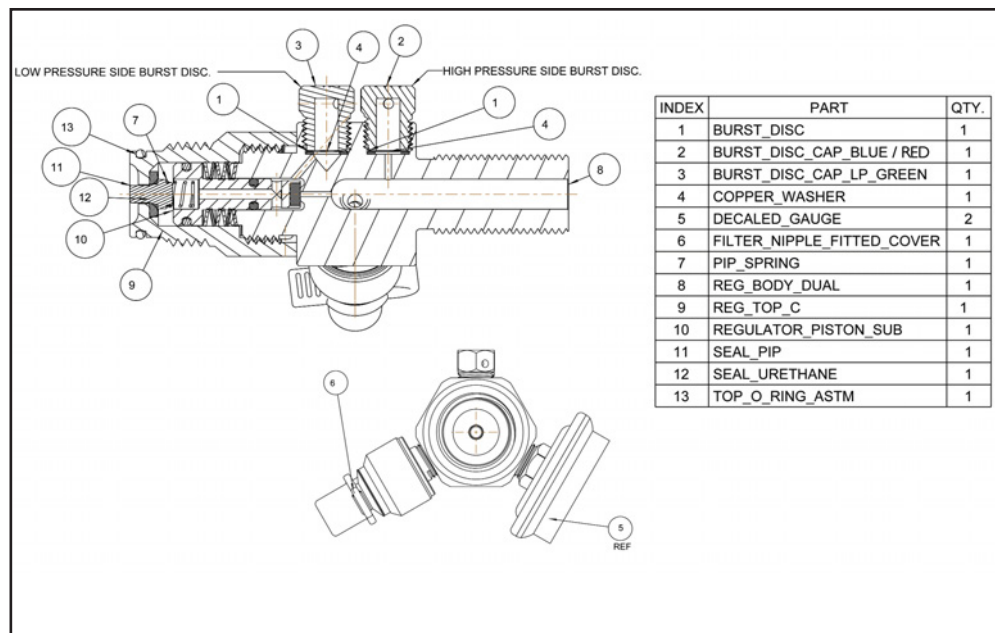

| INDEX | PART | QTY. |
|-------|----------------------------|------|
| 1 | BURST_DISC | 1 |
| 2 | BURST_DISC_CAP_BLUE / RED | 1 |
| 3 | BURST_DISC_CAP_LP_GREEN | 1 |
| 4 | COPPER_WASHER | 1 |
| 5 | DECALED_GAUGE | 2 |
| 6 | FILTER_NIPPLE_FITTED_COVER | 1 |
| 7 | PIP_SPRING | 1 |
| 8 | REG_BODY_DUAL | 1 |
| 9 | REG_TOP_C | 1 |
| 10 | REGULATOR_PISTON_SUB | 1 |
| 11 | SEAL_PIP | 1 |
| 12 | SEAL_URETHANE | 1 |
| 13 | TOP_O_RING_ASTM | 1 |

Installation

ONLY ATTEMPT ANY INSTALLATION OR MAINTENANCE IF YOU ARE A FULLY COMPETENT QUALIFIED PERSON. IF IN ANY DOUBT RETURN THE UNIT TO ARROW PRECISION LIMITED.

In normal use it is recommended that the regulator is fitted into the gas cylinder with the application of thread-locking compound. The regulator assembly should be tightened into the cylinder with a torque wrench set accurately to 35Lbs.Ft.

Apply thread locking compound to the male 5/8thx18 UNF end of the regulator body, two lines down opposite sides is sufficient, do not use an excessive amount. Clamp the cylinder in a pipe vice with protection on the jaws to prevent damaging the cylinder; ie. a rubber mat. Set a torque wrench to 35 Lbs.f/ft and tighten the regulator into the cylinder using a special socket as shown.

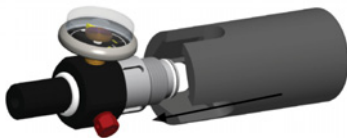

Filling

Connect the female QD fitting to male QD fitting on the regulator and slowly open the filling valve. Use only clean dry air filling the assembled cylinder and regulator; a gauge is fitted to the regulator so watch it as you fill so as not to go over the pressure rating.

Once the correct pressure is reached, the filling valve is closed and the line is vented. The QD can then be detached.

Use only good quality filling fittings and ensure the female is positively engaged with the male nipple. The hose length connecting the filling nipple the source should be kept a minimum in case of a 'blow-off'. This prevents potential hose whip and risk of serious injury to minimum. Good quality fittings are available from Arrow-Precision Ltd.

Filling the bottle too quickly or 'flash filling' is not recommended. A rate of 100 psi/sec is recommended. Fast filling is irresponsible as it causes heating and increases the likelihood of lubricant ignition with disastrous results! If a cylinder is going to fail, fast filling is when it most likely to do so!

The filling nipple contains a 50 micron air filter to prevent contaminants from entering the air system and causing damage to the cylinder or regulator working parts. However care should be taken to try and avoid dirt entering fill nipples, use a dust cap. The back-check device is an 'o' ring free design to prevent problems associated with high filling rates and o-ringed back-check designs.

A safety device or bursting disc is fitted to the regulator to prevent over filling and dangerous pressures developing above the rating for the cylinder. Always check the burst disc pressure rating complies with cylinder rating and use only discs supplied by Arrow-Precision Ltd. Eye protection is recommended whilst working with compressed gases

Maintenance

ONLY ATTEMPT ANY INSTALLATION OR MAINTENANCE IF YOU ARE A FULLY COMPETENT QUALIFIED PERSON. IF IN ANY DOUBT RETURN THE UNIT TO ARROW PRECISION LIMITED.

Make absolutely certain that all the air in the cylinder has been released before attempting to dismantle the regulator. If you feel unsure about any of these procedures do not attempt it, return the unit to Arrow Precision for servicing.

The regulator contains a number of precision components that must be given adequate care. Therefore follow these guidelines:

- Avoid damage - **DO NOT DROP**
- Use correct tools to disassemble.
- Clean, inspect for signs of damage, and wipe with a lightly oiled rag after use.

All tools required to disassemble the regulator and the components of the regulator, which are all replaceable, are available from Arrow Precision Ltd.

A standard 1/16th allen key is used to loosen the cap locking grubscrew, then remove the grub screw. Thread locking compound is used to secure the cap to the body so it will be necessary to use heat to release the compound.

A 'C' spanner is then used to loosen and unscrew the regulator cap away from the regulator body. The reg bobbin and beleville spring pack will come away still inside the cap.

The bobbin assembly can be pushed out of the cap by applying pressure to sealing pip using a 7/6th 'T' handled allen key.

Be careful not allow the assembly to fly out and hit the floor! The reg sealing pip and cap seal can now be accessed.

Servicing the bobbin assembly entails removing the 'O' rings and replacing them. The spring pack should be also replaced.

PLEASE TURN OVER FOR FULL MAINTENANCE INSTRUCTIONS WITH DIAGRAMS.

Spares

Spares kit available containing the following:

| | |
|-------------------|-----------------|
| C spanner | 1 |
| Beleville Stack | 1 (contains 8) |
| Grub screw | 1 |
| O ring BS015 PU90 | 1 |
| Regulator piston | 1 |
| Seal urethane | 1 |
| Spring | 1 |
| Seal pip | 1 |

Filter nipple

Piston sub assembly

| Part Name | Qty |
|-----------------------|-----|
| Filter retaining body | 1 |
| Sintered filter | 1 |
| Delrin backcheck | 1 |
| Spring | 1 |
| Quad ring BS012 | 1 |
| Fill nipple cap | 1 |

| Index | Part Name | Qty |
|-------|------------------|-----|
| 1 | Reg bobbin | 1 |
| 2 | BS006 O ring | 1 |
| 3 | O ring BS012 | 1 |
| 4 | Delrin face seal | 1 |

PLEASE READ ALL ENCLOSED INSTRUCTIONS BEFORE ATTEMPTING ANY INSTALLATION OR MAINTENANCE OF THIS PRODUCT.

SERIOUS INJURY OR DEATH CAN OCCUR WHEN DEALING WITH COMPRESSED GAS EQUIPMENT.
© Copyright Arrow Precision Limited 2007

STEP 1 Bobbin Sub Assembly

Install O rings on bobbin Reg 025:
BS012 Part No. Reg060
BS006 Part No. Fillr0340
FillR020 Face Seal.

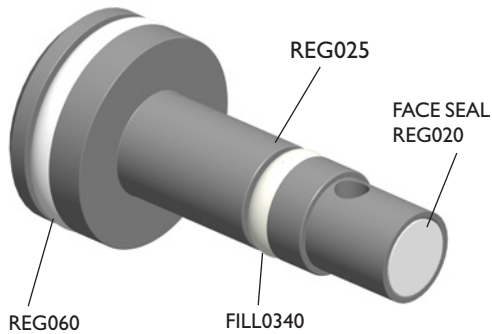

STEP 2

Install 8 spring washers onto the bobbin spindle ensuring they are correctly oriented, that is, angular face facing angular face. As shown below:

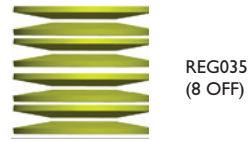

Use synthetic grease (super lube) of the Synco Chemical Corporation to lubricate the bore of the regulator body and the O rings of the bobbin.

Ease the assembled bobbin into the regulator body, as shown below:



STEP 3

Insert the spring Reg 015 and sealing pip Reg 010.

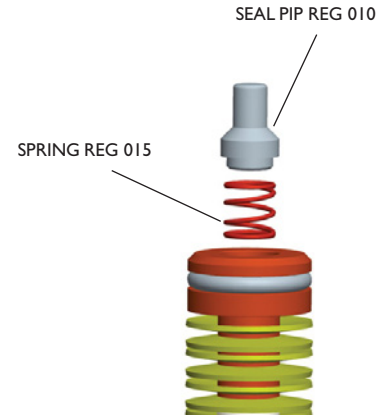

STEP 4

Apply some synthetic grease to the bore of the regulator cap Reg 005 and to polyurethane seal Sov2090 which can then be adhered to bottom of the bore. Ensure the angled outer edge of the seal aligns with chamfer at bottom of hole.

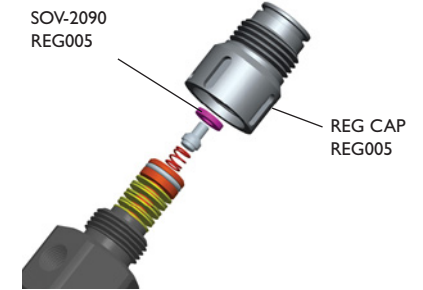

Then ease the cap down over the bobbin assembly ensuring the O ring Reg 060 enters the bore without damage or nicking. Once fully over the bobbin some green high strength thread locking compound can be applied to the thread and the cap screwed down. The cap can then be tightened down with a "C" spanner (Gedore No.40), the grub screw Reg 070 is then screwed in using a 1/16th allen key.

STEP 5

Clamp regulator body using soft jaws on each end taking care not to over tighten vice. Install back-check slug: REG 125 and return spring: S 1390 into filter retaining body: REG 120 Using 1/2" open ended spanner screw in filter retaining body into regulator body with inserted back-check slug, (ensuring it is in the 1/8th NPT tapped hole) apply some pipe sealing PTFE tape to 1/8th NPT end, tighten until approx. 0.11" - 0.12" between body and shoulder: Insert sintered filter: REG 140 then install Quad ring: REG 120 onto retaining body shoulder. Insert an 1/8th allen key into the end of filter fill nipple male: REG 130, and tighten on.

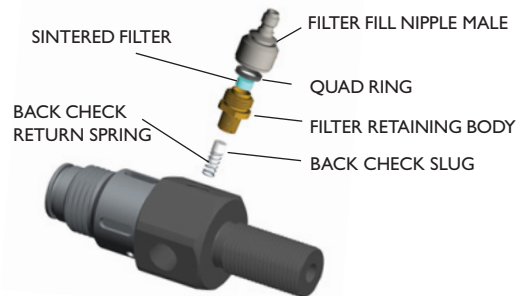

STEP 6

Install the burst disc cap assembly, place copper washer REG075 into 3/8th UNF tapped hole, then place a bursting disc REG085 on top, screw in the burst disc cap REG100, torque to 75 Lb/in using torque wrench. There are two anodised colour options for this part, red and blue. Red to fitted for 300 BAR regulators, blue for 200 BAR.

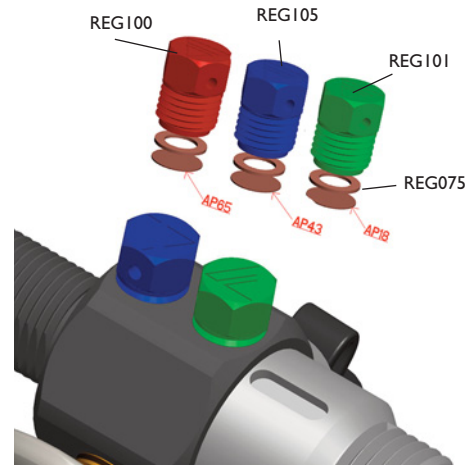

STEP 7

Rotate the assembly and now fit the gauge FILLR0311, using some pipe sealing compound carefully applied to 1/8th NPT tapped hole.

Note the orientation of the fill nipple and the gauge should as follows:

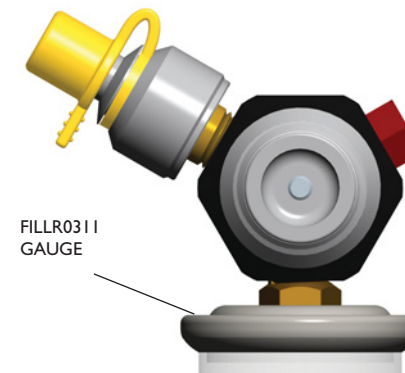

STEP 8

Install O ring on to regulator cap:

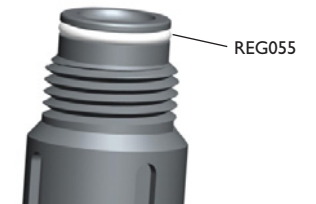

Install bottle O ring using O ring tool:



Fit dust cap fill nipple. If applicable.